



Visit our homepage  
for additional support  
[parker.com/pmde](http://parker.com/pmde)

Bulletin MSG30-3254-INST/UK

# Installation and setup manual

## Electro-hydraulic control for serie PVplus

Pump design series 44-45-46-47,  
compensator design series 45

Effective: July 1st, 2021  
Supersedes: March 1st, 2017

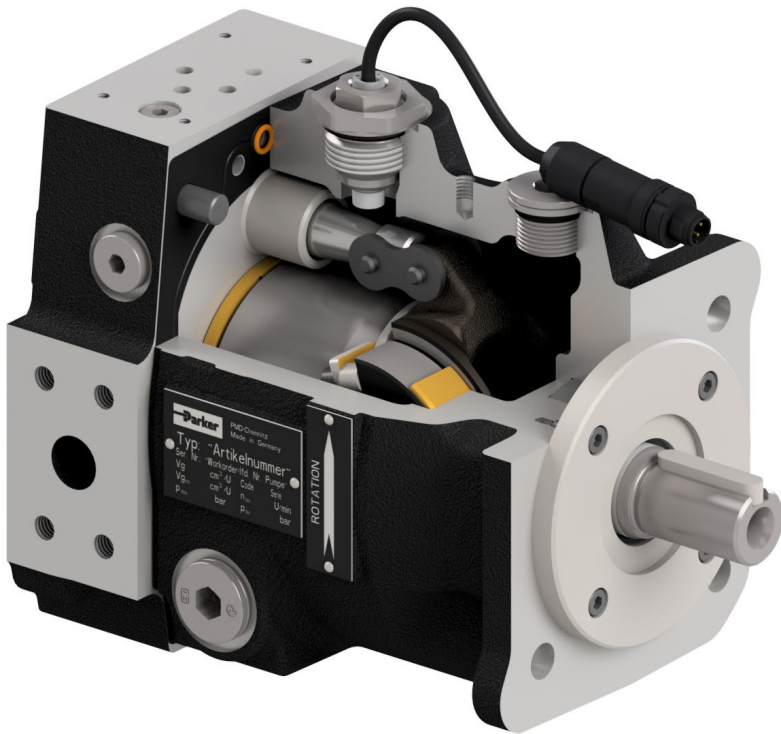

ENGINEERING YOUR SUCCESS.

## Setup manual for electro hydraulic proportional controls for axial piston pumps, PV family

### Contents

1.	Table of available electro hydraulic controls.....	3
2.	Proportional displacement control, code ...FDV (old: FPV) .....	3
3.	Proportional displacement control with pressure compensation, codes ...UDR, ...UDK (old: UPR, UPK) .....	6
4.	Proportional displacement control with closed loop pressure control, code ...UDM (old: UPM) .....	8
5.	Preload valve for proportional controlled pumps, code PVAPV.....	10
	Table 1: Main dimensions - preload manifold .....	11
6.	External pilot pressure supply .....	12
7.	Quick pressure relief with quick unload valve, code PVAPSE* in combination with controls codes ...UDS resp. UDQ .....	13
8.	Preload and quick unload manifold PVAPVE* in combination with compensator codes ...UDP resp. ...UDF .....	14
	Table 3: Main dimensions of the preload and quick unload manifold.....	15
9.1	Basic adjustment of CIP sensor .....	16
9.2	Basic adjustment LVDT .....	18
9.3	Basic adjustment control valves .....	19
10.	Connecting diagram for proportional displacement control; Code ...FDV .....	20
11.	Connecting diagram for p/Q-control; Codes ..UDR, ...UDK, ...UDM, ...UDS, ...UDQ, ... UDP and ...UDF .....	21
12.	Cables and connections .....	22
13.	Trouble shooting guide .....	24

### Notes:

The compensator / control ordering codes shown represent the last three digits in the pump ordering code (di-gits 13 to 15).

**1. table of available electro hydraulic controls**

Electro hydraulic controls			
Code		Control designs	
F	D	V	closed loop displacement control with <b>PVCMD1FB***</b> valve, no pressure compensation, standard design from 07.2015
U	D		closed loop displacement control with <b>PVCMD1FB***</b> valve, with pressure compensation, standard design from 07.2015
Code		option	
		R	pilot operated pressure control, NG6 interface
		K	as option R, additional proportional pressure valve <b>PVACRE***K**</b> mounted
		M	as option K, additional pressure sensor <b>PVACMS</b> mounted for closed loop pressure control
		P	pilot operated pressure control, NG6 interface, for pre load and quick unload manifold
		F	as option P for pre load and quick unload manifold, additional <b>PVACMS</b> and <b>PVACRE***K**</b> mounted for closed loop pressure control
		S	pilot operated pressure control, NG6 interface, for quick unload manifold
		Q	as option S for quick unload manifold, additional <b>PVACMS</b> and <b>PVACRE***K**</b> mounted for closed loop pressure control

**2. Proportional displacement control, code ...FDV (old: FPV)**

**FDV Function description**

The proportional displacement control allows a continuous variation of the pump displacement according to an electrical input command. A contactless inductiv position sensor (CIP-Sensor) measures the position of the servo piston and provides an information on the actual displacement (signal, displacement) to the control

electronic. The servo piston is kept by the servo spring and the pump outlet pressure on its annulus area at maximum displacement. The larger piston area is pressurized by the control valve.

Figure 2 shows the circuit diagram of a pump with this control.

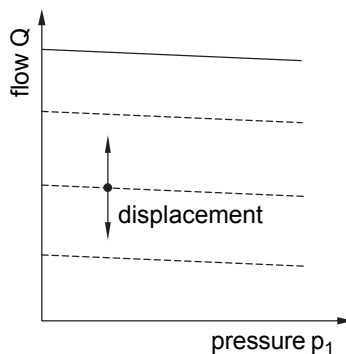

**Figure 1** pQ Diagram ...FDV (old:FPV)

**FDV - Function**

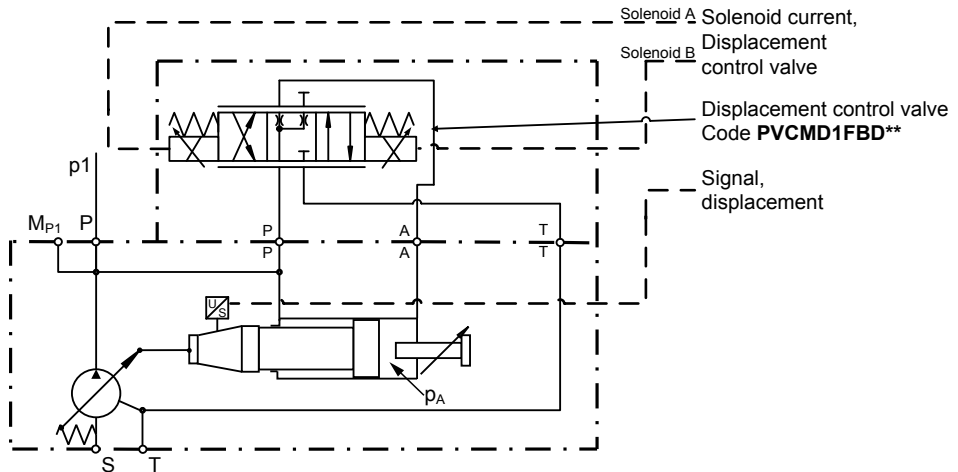

**Figure 2:** Circuit diagram...FDV control

The control valve contains a control spool, which is moved by two proportional solenoids. The valve's hydraulic neutral point is given by the electronic control module. According to the area ratio of the servo piston, the control pressure  $p_A$  is approximately 25 % of the pump outlet pressure  $p_1$ .

Solenoid A is driven by the electronic module for a flow command of 100 %. The spool connects thereby port A with the pump housing (Port T). The oil out of the large piston area drains off, the pump is swashing to maximum displacement. Solenoid B is activated in case of 0 % flow command. The pump outlet pressure  $p_1$  on the large servo piston area downstrokes the pump

to minimum displacement. This requires a pump outlet pressure  $p_1$  of at least 15 bar.

If this pressure cannot be maintained, special arrangements for a proper displacement control are required (please refer to chapter 4). Without an appropriate load pressure the pump will stay at full displacement.

The ordering code for a single control valve is: PVCMD1FB\*\*\* the first \* indicates the mounting option ( with interface plate / elbow manifold ). The two \* at the end indicate seal option and screws option (For details please see the compensator spare parts list PVI-PVC).



**Figure 3:** Electronic module **PQRDXXA-Z10**

#### 4. Electronic module **PQRDXXA-Z10** – Function

To control the proportional solenoid the electronic module PQRDXXA-Z10 is offered. This module is able to control all PV sizes and all control option.  
 Figure 3 shows this module from the outside, figure 4 the electronic control circuit.

For further information please see Bulletin MSG30-3255-INST/UK

#### Circuit diagram

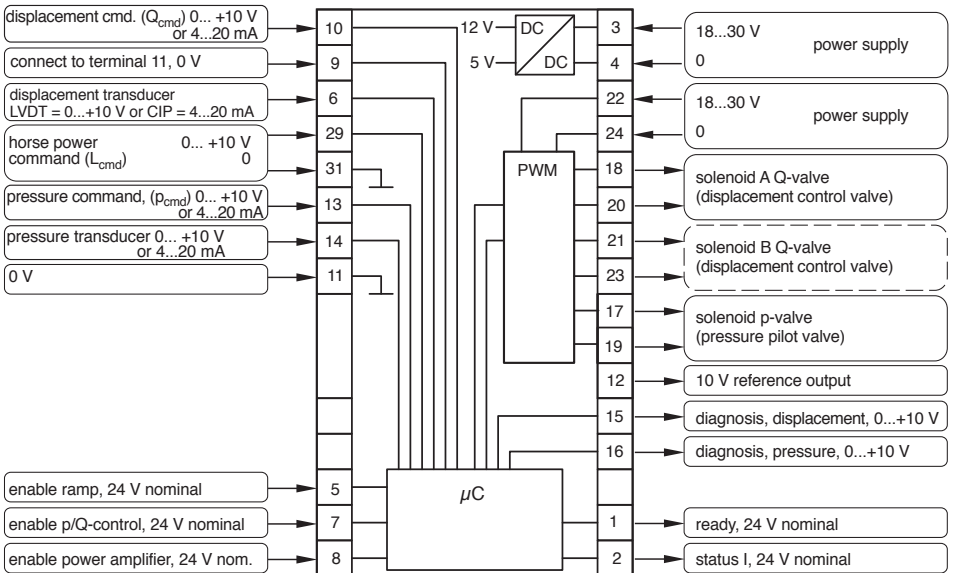

**Figure 4:** Circuit diagram for electronic module **PQRDXXA-Z10**

**3. Proportional displacement control with pressure compensation, codes ...UDR, ...UDK (old: UPR, UPK)**

The compensator code ...UDR (**PVCM<sup>D</sup>1FBU<sup>\*\*</sup>** + open NG6 pattern), ...UDK (**PVCM<sup>D</sup>1FBU<sup>\*\*</sup>** + **PVACRE<sup>\*\*\*</sup>K<sup>\*\*</sup>**) include a pressure compensation, which can override the proportional displacement control. This is achieved by combining a second control valve (remote pressure compensator) with the displacement control valve. Figure 5 show the hydraulic circuit of the UDK option.

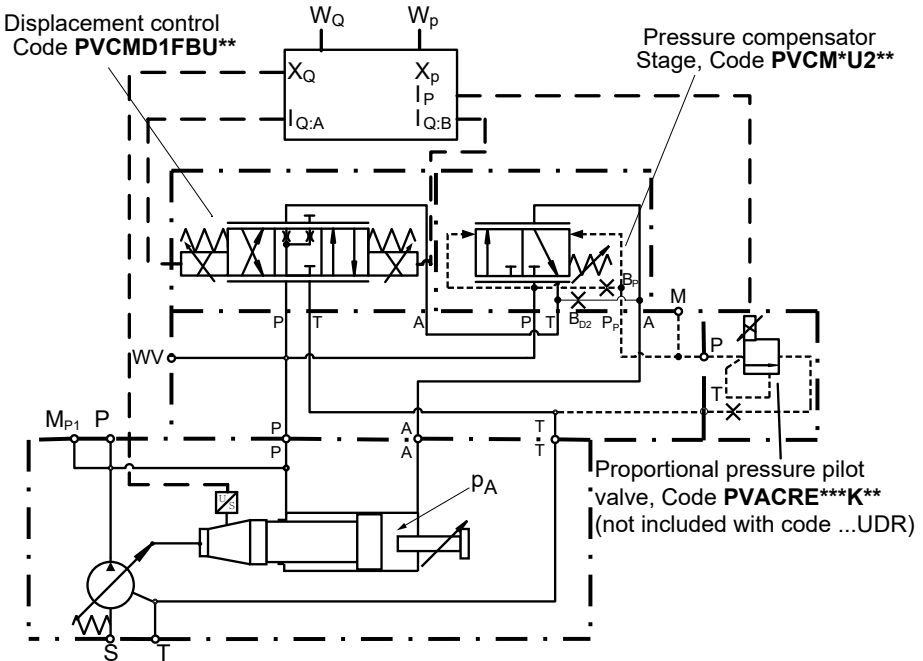

- X<sub>Q</sub> = signal, displacement
- I<sub>Q:A</sub> = solenoid current A, displacement control valve
- I<sub>Q:B</sub> = solenoid current B, displacement control valve
- I<sub>P</sub> = solenoid current, pressure pilot Valve
- W<sub>Q</sub> = command, displacement
- W<sub>P</sub> = command, pressure

**Figure 5:** Hydraulic Circuit of the ...UDR, ...UDK control

## Function description UDR / UDK (old: UPR / UPK)

The position of the control spool of the pressure compensator is controlled by the pressure drop across the pilot orifice Bp and by the compensator spring. The nominal control pressure difference is factory-set to a value of  $15 \pm 1$  bar.

As long as the pressure setting of the pilot valve (in figures 5: proportional pressure valve **PVACRE\*\*\*K\*\***) is not yet reached, the control valve spring keeps the control spool in the position shown. The control port of the displacement control valve is connected to the large servo piston area and controls the position of the servo piston.

The displacement control operates as described in chapter 2. The adjustment of the control pressure is done between the control spool and control orifice.

When the set pressure of the pilot valve is reached, this valve opens and control flow from the pump outlet is passing the pilot orifice Bp and the pressure pilot valve before returning to the pump drain line. That creates a pressure drop across pilot orifice Bp. If this pressure drop reaches the 15 bar setting of the compensator, the control spool of the pressure stage is in its control position.

That leads to a reduction of the pump displacement in order to keep the pump outlet pressure constant. As the displacement control wants to keep the pump at the set displacement the proportional solenoid is powered with nominal current. That connects the control port of the displacement control valve with the pump case (port T).

The control spool of the pressure stage now controls the servo piston position by using the control orifice B<sub>D2</sub> for pressure dividing. Pressure control is achieved as with a standard remote compensator. It is mandatory, that the displacement setting of the displacement control stage is high enough, to cover the flow requirements of the system, the pump and the control valves to maintain the desired pressure. The following valve is to be used with this mod-

ule: **PVACRE\*\*\*K\*\***. Other valve models can lead to instability problems or malfunction of the control.

This valve is designed for a nominal pressure of 350 bar. By using the MAX adjustment at the control module, the input command range can easily be adjusted to any smaller nominal system pressure. In this way also for these lower pressures full resolution of the input command can be achieved.

For basic adjustment of the control valves and the displacement transducer see chapter 9. For electrical connection and cable requirements see chapter 12.

**Note:** Parker has decided for this design with a separate hydraulic-mechanically operated remote pressure compensator, which overrides the proportional displacement control for three reasons:

1. Piston pumps of the PV series have a large servo piston. That offers several advantages. On the other hand the servo piston has a high flow demand for compensation. A hydraulic mechanical pressure compensator – as used here – can provide much higher control flows, than a proportional directional control valve used by other pump models, where this valve also provides pressure control basing of the signal of a pressure transducer.
2. The hydraulic-mechanical control valve „senses“ a pressure peak in the system, as the pressure acts direct on the control spool. Depending on the actual system pressure very high forces are available to operate the spool. Therefore this control rarely will tend to stick or malfunction, as proportional directional control valves may do under contaminated fluid conditions.
3. The pressure control using a proportional pressure control valve to pilot it, does not require a pressure sensor at the pump outlet. Nevertheless a closed loop pressure control can be offered if required (see next chapter).

**4. Proportional displacement control with closed loop pressure control,  
code ...UDM (old: UPM)**

With compensator ordering code ...UDM a pressure sensor and a proportional pressure valve is combined with the remote pressure control stage. That realizes a closed loop pressure control. It also offers the option of an electronic horse power limitation. The hydraulic circuit for these control option are shown in figure 6.

The pressure sensor included in the shipment is of the Parker model **PVACMS** (SCP01-600-24-06). Also included in the shipment is a proportional pressure pilot valve of the ordering code **PVACRE\*\*\*K\*\***. The hydraulic function is described in the recent chapter. There are no differences except the pressure sensor.

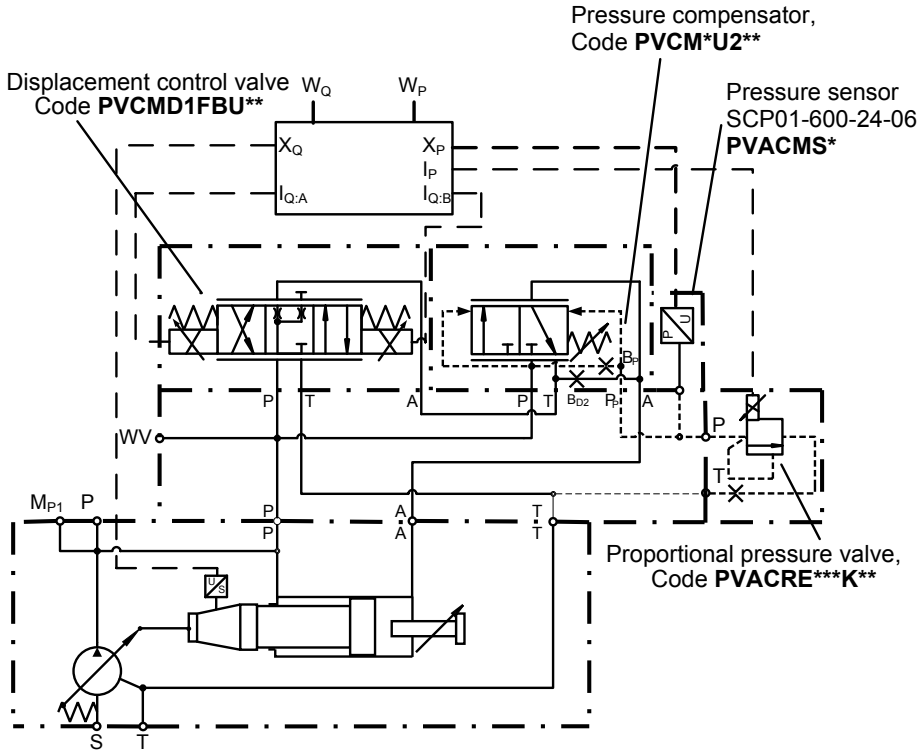

- $X_Q$  = signal, displacement
- $I_{Q:A}$  = solenoid current A, displacement control valve
- $I_{Q:B}$  = solenoid current B, displacement control valve
- $X_P$  = signal, pressure
- $I_P$  = solenoid current, pressure pilot Valve
- $W_Q$  = command, displacement
- $W_P$  = command, pressure

**Figure 6:** Hydraulic Circuit of ...UDM control



As shown in figure 6, the pressure sensor is positioned in the pilot circuit. According to the differential pressure adjusted at the compensator valve, the system pressure is higher than the controlled pressure.

This concept avoids stability problems with the control loop and the necessity of an external adjustment of the control loop. On the other hand there are additional measures necessary (e.g.: command signal correction), if linearity between input (command signal) and output (system pressure) is required.

Figure 7 shows the typical behaviour of pilot pressure  $p_p$  and system pressure  $p_1$  as function of the input signal.

The digital control module offers the required signal correction to compensate for this effect. The standard module parameter sets already include this feature for the factory set pressure differential of 15 bar.

For other differential settings see module operating instructions.

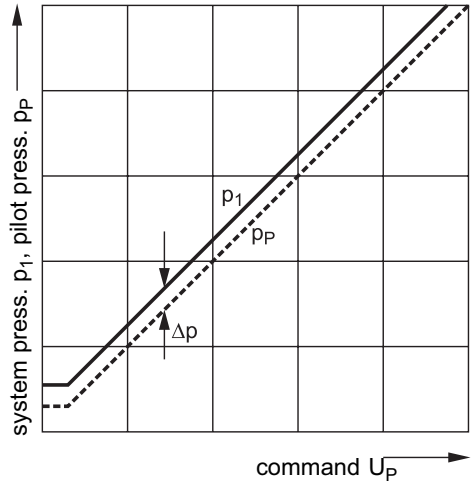

**Figure 7:** Pressures vs input signal

$p_1$  = pressure at pump outlet, system pressure  
 (=  $p_p + \Delta p$ )

$\Delta p$  = compensator differential  
 (factory setting 15 bar)

$p_p$  = pressure at pilot valve, closed loop controlled pressure

**5. Preload valve for proportional controlled pumps, code PVAPVV...**

As already mentioned in chapter 1, a proportional controlled variable displacement pump needs always a minimum outlet pressure of approx. 20 bar, to down stroke the pump against the servo spring force.

In some applications and especially at small displacement settings that is not always given. Two possibilities to solve this issue are described in the following chapters:

If and external auxiliary pressure is available, this can be used to control the pump at low outlet pressure. This method is explained in chapter 6. The other option is the use of a preload valve (sequence valve).

Figure 8 is showing the hydraulic circuit of a

pump with ...UPR control, using a preload valve. The preload valve is offered as a manifold, that can directly be flanged to the pressure port of the pump. The ordering code is **PVAPVV\***. The \* stands for the frame size of the pump, the screw option and the seal material.

The preload valve is also available as slip in cartridge valve according to DIN 24 342.

Because of the pilot valve characteristic the opening pressure  $p_1$  is approx. 20 bar. The port  $M_{p1}$  can be used to get under all working conditions a pressure of 20 bar e.g. to pilot valves with external pilot pressure supply. At approx. 25 bar system pressure the valve is fully open (pressure drop < 1 bar).

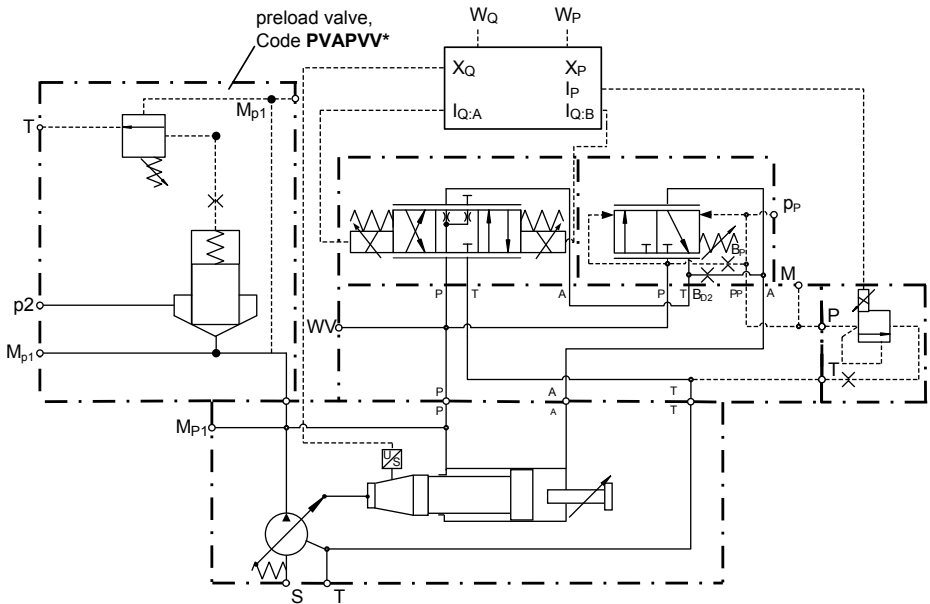

- XQ = signal, displacement
- IQ:A = solenoid current A, displacement control valve
- IQ:B = solenoid current B, displacement control valve
- XP = signal, pressure sensor
- IP = solenoid current, pressure pilot Valve
- WQ = command, displacement
- WP = command, pressure

**Figure 8:** Hydraulic circuit of a pump with ...UDK with preload valve control

Figure 9 shows the preload manifold for direct mounting to the pressure port of the pump. It takes screws with the length L to mount it to the pump. L includes the length screwed into the pump end cover.

Input and output are designed as flange ports according to ISO 6162 and fit direct to the according PV frame size. Table 1 shows the main dimensions.

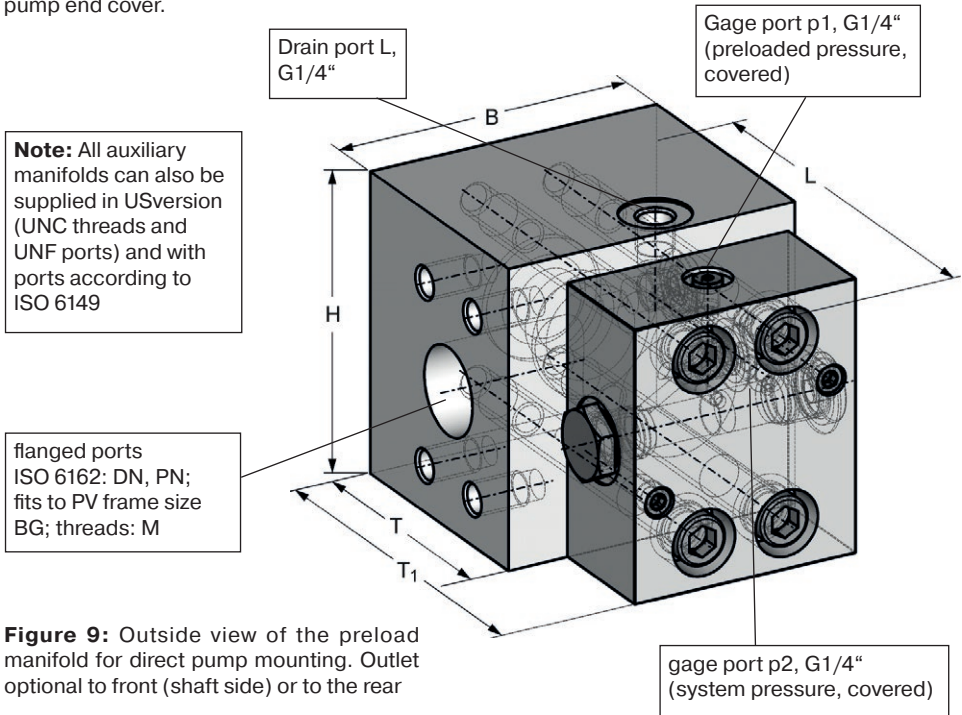

**Figure 9:** Outside view of the preload manifold for direct pump mounting. Outlet optional to front (shaft side) or to the rear

**Table 1: Main dimensions - preload manifold**

dimension	BG1	BG2	BG3	BG4	BG5	BG6*
H[mm]	100	100	110	110	120	120
B[mm]	90	90	100	100	125	125
T[mm]	80	80	92	92	105	105
L[mm]	102	102	122(119*)	122(119*)	136	136
T1[mm]	116	116	137	137	155	155
for size	PV016 - 028	PV032 - 046	PV063 - 092	PV140 - 180	PV270	PV360
DN[mm]	19 (3/4")	25 (1")	32 (1 1/4")	32 (1 1/4")	38 (1 1/2")	38 (1 1/2")
PN[bar]	400	400	400	400	400	400
M	M10	M12	M12 (M14*)	M12 (M14*)	M16	M16
valve insert	DIN E16	DIN E16	DIN E25	DIN E25	DIN E32	DIN E32
Q <sub>nominal</sub> [l/min]	160	160	300	300	550	550

\*1) optional for PV063 – PV180, thread option 4; 2) L = clamping length for screws M

\*2) for BG6 PV 360 the preload manifold of BG5 is used

## 6. External pilot pressure supply

The alternative solution is, to supply the control circuit from an external auxiliary pilot pressure supply circuit. The servo system is disconnected from the pump outlet (plug inside of the pump gage port). The pump outlet pressure is connected via a check valve to the pilot pressure port.

An external source for auxiliary power (capable of a flow of 20 – 40 l/min (depending on pump size) at a pressure of 20 – 30 bar) is also connected via a check valve to the pilot port. Figure 10 shows the hydraulic circuit for this option.

As long as the pump outlet pressure is lower, than the external supply pressure, the control circuit is powered by the external source. When the system pressure exceeds the auxiliary pressure, the control is internally pressurized.

### Please note:

- for pressures below the auxiliary pressure a pressure control is not possible, because the control senses the supply pressure.
- using this option the pump can be operated at 0 bar and dead head. Under these conditions the pump does not provide drain flow and the pump can overheat. Case flushing is necessary.

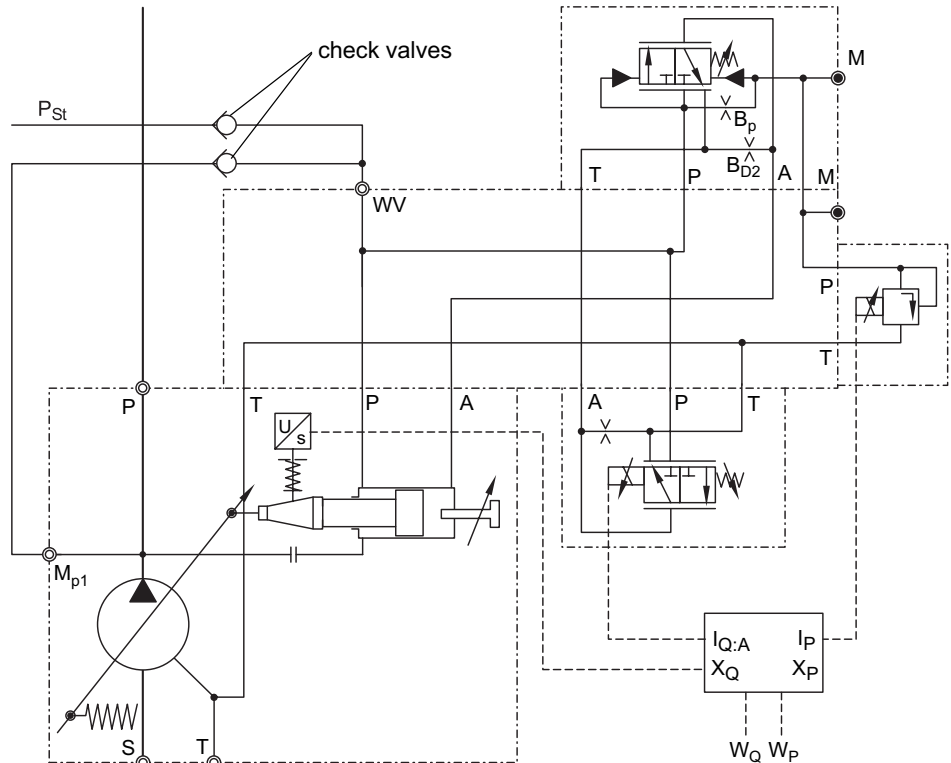

$X_Q$  = signal, displacement  
 $I_{Q:A}$  = solenoid current A, displacement control valve  
 $X_P$  = signal, pressure sensor

$I_P$  = solenoid current, pressure pilot valve  
 $W_Q$  = command, displacement  
 $W_P$  = command, pressure

**Figure 10:** Hydraulic circuit of a pump with external pilot pressure supply

**7. Quick pressure relief with quick unload valve, code R5V\* in combination with controls codes ...UDS resp. UDQ**

When working with proportional pressure controlled pumps, the system pressure does not follow immediately the input signal when switching to a lower pressure setting.

Reason for this is, that a pump can supply flow but cannot take flow to relieve a system. To decrease the pressure in a system, compression volume has to be taken away in order to reduce the pressure. A pump only can be down stroked to deadhead and pressure can only decrease due to leakage and pilot power requirements. That can take up to several seconds.

A direct mounted unload valve, Code R5V\* (complete code, technical parameter and dimensions on request) solves this issue.

Figure 11 is showing the hydraulic circuit of a pump with p-Q control and the quick unload valve.

A 2-way SAE port mounted valve is inserted into the pilot line to the pressure compensator stage. The pilot flow to the proportional pressure pilot valve has to pass two orifices in the poppet and in the cover of this valve. The poppet is kept closed with a 9-bar-spring.

The pressure compensator stage has in this case not the control spool with the internal pilot orifice (Bp), because pilot flow is now supplied externally through the quick unload poppet. The ordering code for this compensator is PVCm\*US\*\*.

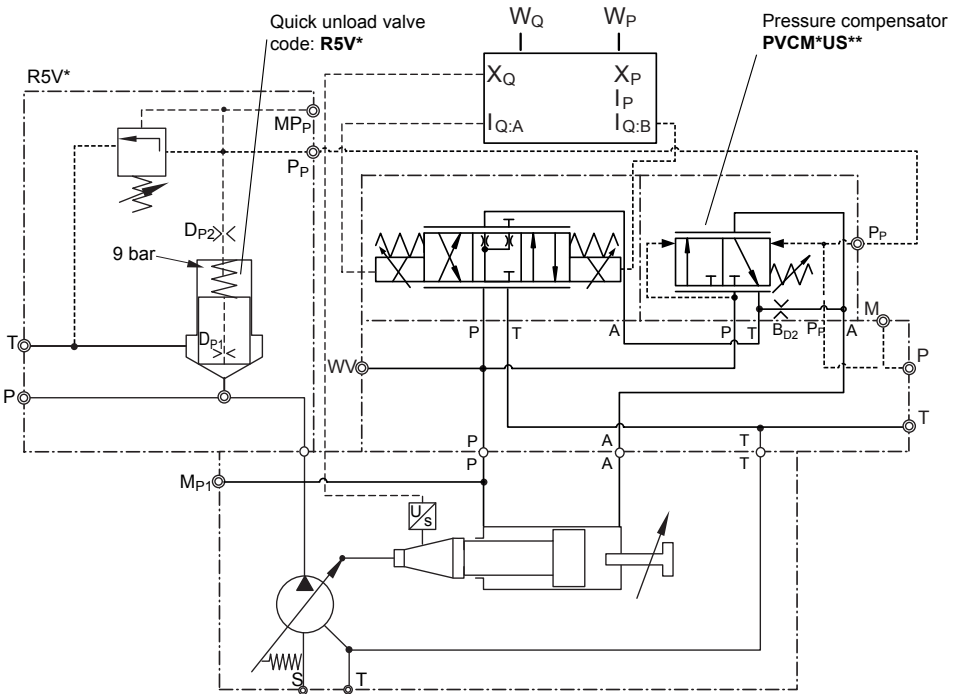

- |   |   |
|---|---|
| X <sub>Q</sub> = signal, displacement                             | I <sub>P</sub> = solenoid current, pressure pilot valve |
| I <sub>Q:A</sub> = solenoid current A, displacement control valve | W <sub>Q</sub> = command, displacement                  |
| I <sub>Q:B</sub> = solenoid current B, displacement control valve | W <sub>P</sub> = command, pressure                      |
| X <sub>P</sub> = signal, pressure sensor                          |   |

**Figure 11:** Hydraulic circuit of the ...UDS control with quick unload valve

**8. Preload and quick unload manifold PVAPVE\* in combination with compensator codes  
 ...UDP resp. ...UDF**

The pump accessory manifold code **PVAPVE\*** combines preload and quick unload function. This manifold is flanged direct to the pressure port of a PV pump. For functional description see the last chapters.

To ensure a correct function under all working conditions and to control immediately the load pressure, the control pressure has to be taken after the preload valve.

Sensing area of the control spool and spring chamber are both to be connected by pipe or

hose to the control ports of this manifold. The hydraulic circuit diagram in figure 12 display this. Both functions are built into one manifold. Figure 13 shows this manifold and table 3 lists the main dimensions.

The dimension L indicates the total length of the mounting bolts and includes the length screwed into the pump end cover.

The hydraulic connections between manifold and pump compensator (ps and pp) are not included in the pump shipment.

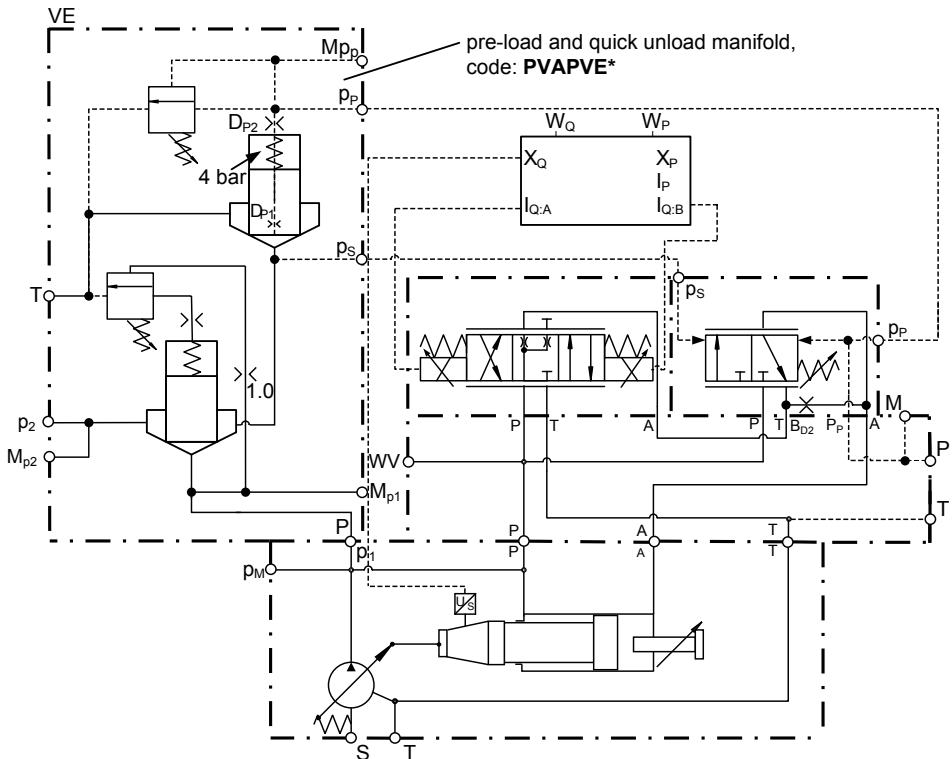

- |  |  |
|--|--|
| $X_Q$ = signal, displacement                               | $I_P$ = solenoid current, pressure pilot valve |
| $I_{Q:A}$ = solenoid current A, displacement control valve | $W_Q$ = command, displacement                  |
| $I_{Q:B}$ = solenoid current B, displacement control valve | $W_P$ = command, pressure                      |
| $X_P$ = signal, pressure sensor                            |  |

**Figure 12:** Hydraulic circuit of the ...UDP control with pre-load and quick unload manifold

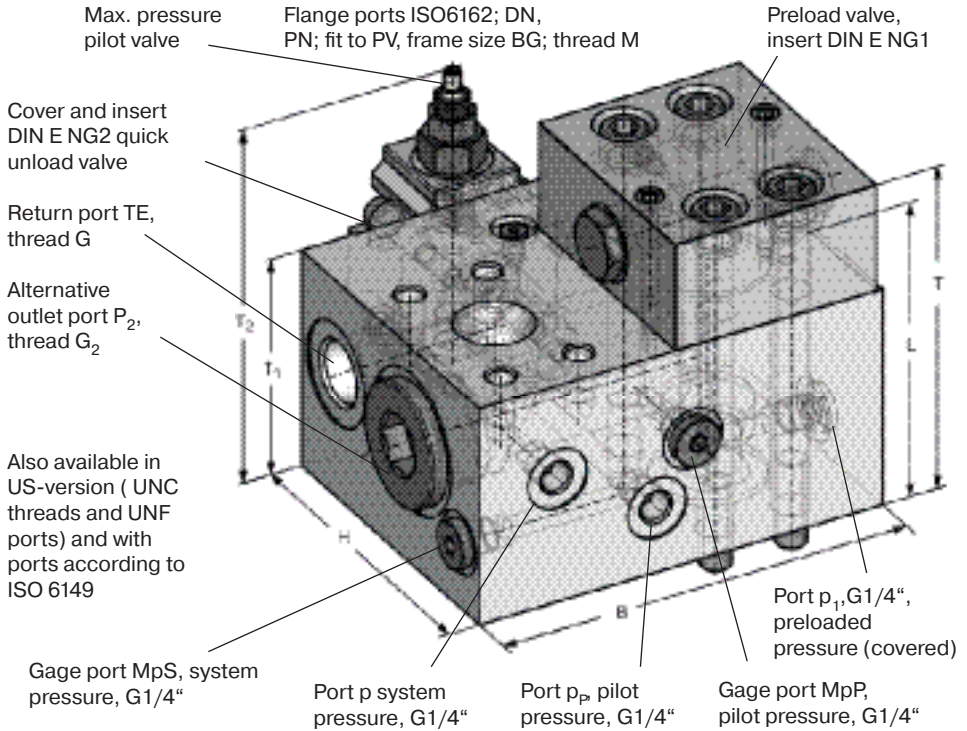

**Figure 13** Preload and quick unload manifold

**Table 3: Main dimensions of the preload and quick unload manifold**

dimension	BG1	BG2	BG3	BG4	BG5	BG6*
B[mm]	125	150	157	157	190	190
H[mm]	105	130	130	130	154	154
T[mm]	80	80	92	92	105	105
L[mm]	105	103	121	121	137,5	137,5
B1[mm]	189	189	196	196	239	239
H1[mm]	166	166	166	166	199	199
T1[mm]	116	116	137	137	155	155
for size	PV016 - 028	PV032 - 046	PV063 - 092	PV140 - 180	PV270	PV360
DN[mm]	19 (3/4")	25 (1")	32 (1 1/4")	32 (1 1/4")	38 (1 1/2")	38 (1 1/2")
PN[bar]	400	400	400	400	400	400
M	M10	M12	M12 (M14*)	M12 (M14*)	M16	M16
valve insertNG1	DIN E16	DIN E16	DIN E25	DIN E25	DIN E32	DIN E32
Qnominal[l/min]	160	160	300	300	550	550
valve insertNG2	DIN E16	DIN E16	DIN E16	DIN E16	DIN E25	DIN E25
Qnominal[l/min]	160	160	160	160	300	300
G (port TE)	1/2"	1/2"	1/2"	1/2"	3/4"	3/4"
G2 (opt. outlet)	3/4"	1"	1 1/4"	1 1/4"	1 1/2"	1 1/2"

\*1) optional for PV063 – PV180, thread option 4

\*2) for BG6 PV360 the manifold of BG5 is used





7. Push button on teach adapter for 1 second → 0 % displacement value is defined [4 mA], LED on sensor flashes 4 times per second  
**Attention:** After teaching 0 % displacement value the sensor is given an undefined signal between 4 and 20 mA.
8. Set the nominal value for the pump displacement to 100 % so that the pump is in max displacement. The displacement of the pump can be checked with the help of a flow measuring device. The maximum displacement is reached, if the displacement / flow does not further increase, even when the input command is still raised.

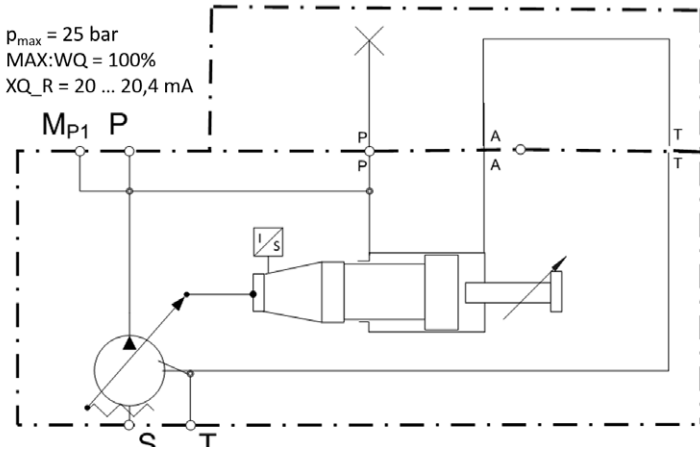

Figure 15: Hydraulic sheme for pump in 100 % displacement

9. Push button on teach adapter for 1 second → 100 % displacement value is defined [20 mA], LED on sensor emits a permanent light signal.
  10. Disconnect teach-adapter and sensor and reconnect sensor with electronic control module.
- Attention:** The teach process needs to be finished within 2 minutes. Otherwise the sensor will reset to the previous setting.
- Note:** If the teach button is pressed for 8 seconds, all settings are deleted, and the sensor is reset to the factory settings.

## 9.2 Basic adjustment LVDT

The inductive position transducer for displacement feedback (LVDT) and the compensator valves are factory preset and the settings are secured. New or readjustment is only necessary after repair.

LVDT for displacement feedback:

Prior to a basic setting the adjustment of the armature length is to be checked / readjusted (see figure 16). The exact dimension for this setting is given in table 4:

**Table 4:** setting dimensions LVDT core

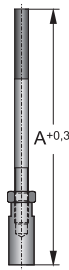

Size	Size	Serie 45
1	PV016-028	73.5
2	PV032-046	73.5
3	PV063-092	75.0
4	PV140-180	75.0
5	PV270	75.0
6	PV360	75.0

Size	voltage	size	voltage
PV016	6.34 V	PV063	7.12 V
PV020	6.06 V	PV080	6.48 V
PV023	5.87 V	PV092	6.10 V
PV028	5.50 V	PV140	5.24 V
PV032	6.40 V	PV180	3.83 V
PV040	5.70 V	PV270	4.06 V
PV046	5.43 V	PV360	4.06 V

**Figure 16:** Setting dimension A for LVDT armature

The adjustment is secured by a removable glue. A new setting again has to be secured to avoid uncontrolled re-setting.

At full upstroked pump the mechanical adjustment can be verified: The voltage at the LVDT output (pin 25 at the control module) should have a value as given in the table below ( $\pm 0,2$  V).

### Zero adjustment:

Next the zero adjustment of the LVDT is to be checked. The LVDT and the solenoid of the displacement control valve are to be connected according to chapter 9 to the electronic control module.

At running pump the command for the displacement is to be set to 0 and the pressure relief valve of the circuit / test rig has to be set to a pressure  $> 25$  bar. All other connections / valves in the hydraulic circuit are to be closed.

The pump then will down stroke to deadhead at the minimum pump compensating pressure ( $10 \pm 2$  bar). By setting the zero adjustment potentiometer (see figure 17) at the LVDT the diagnosis output of the control module is to be set to 0 V, as the actual displacement is the minimum displacement that can be controlled. After adjustment the potentiometer **must** be sealed again.

### MAX-adjustment:

Next the command for the displacement is to be increased, until the maximum displacement of the pump is reached. That can either be monitored by using the diagnosis output or a flow meter at the pump outlet. The maximum displacement is reached, if the displacement / flow does not further increase, even when the input command is still raised.

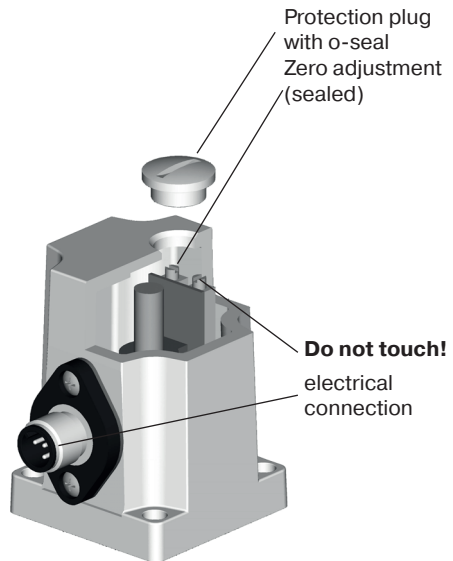

**Figure 17:** inductive position transducer (LVDT), outside view

If the actual value gets 10V before the pump is full stroked, the LVDT parameter need to be reset. If the actual value is below 10V and the pump is already full stroked, the LVDT parameter need to be reset as well.

### 9.3 Basic adjustment control valves

See also Installation and Start-Up Manual for the digital control module PQDXXA-Z10.

**Caution: the proportional displacement control, code ...FDV (old: FPV) does not include a pressure compensation. Therefore the hydraulic circuit needs to be protected with a pressure relief valve (safety valve). This valve has to be layed out for full pump flow.**

The remote pressure compensation stage of the p-Q-controls codes ...UDR, ...UDK, ...UDM, ...UDS, ...UDP und ...UDF (old: ...UPR, ...UPK, ...UPM, ...UPS, ...UPQ, ...UPP and UPF), refered chapters 2 to 7, is adjusted as follows.

The factory setting for the differential pressure is  $15 \pm 1$  bar. For re-adjustment two pressure gages / transducers are required. The differential pressure to be adjusted is the difference between the two pressures on both sides of the control spool of the pressure compensator stage in a control situation. For compensator codes ...UDP and UDF (old: UPP and UPF) this is the difference between the pressure  $p_F$  on the sensing side and the pilot pressure  $p_R$  (see figure 12).

For all other codes it is the difference between pump outlet pressure  $p_1$  and pilot pressure  $p_R$ . The leads to a minimum compensation pressure of 15 bar at completely unloaded spring chamber.

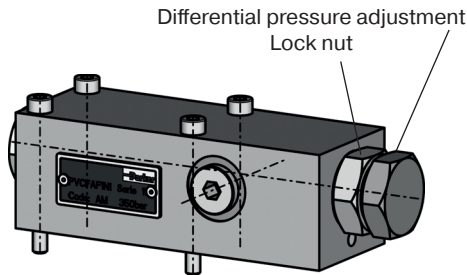
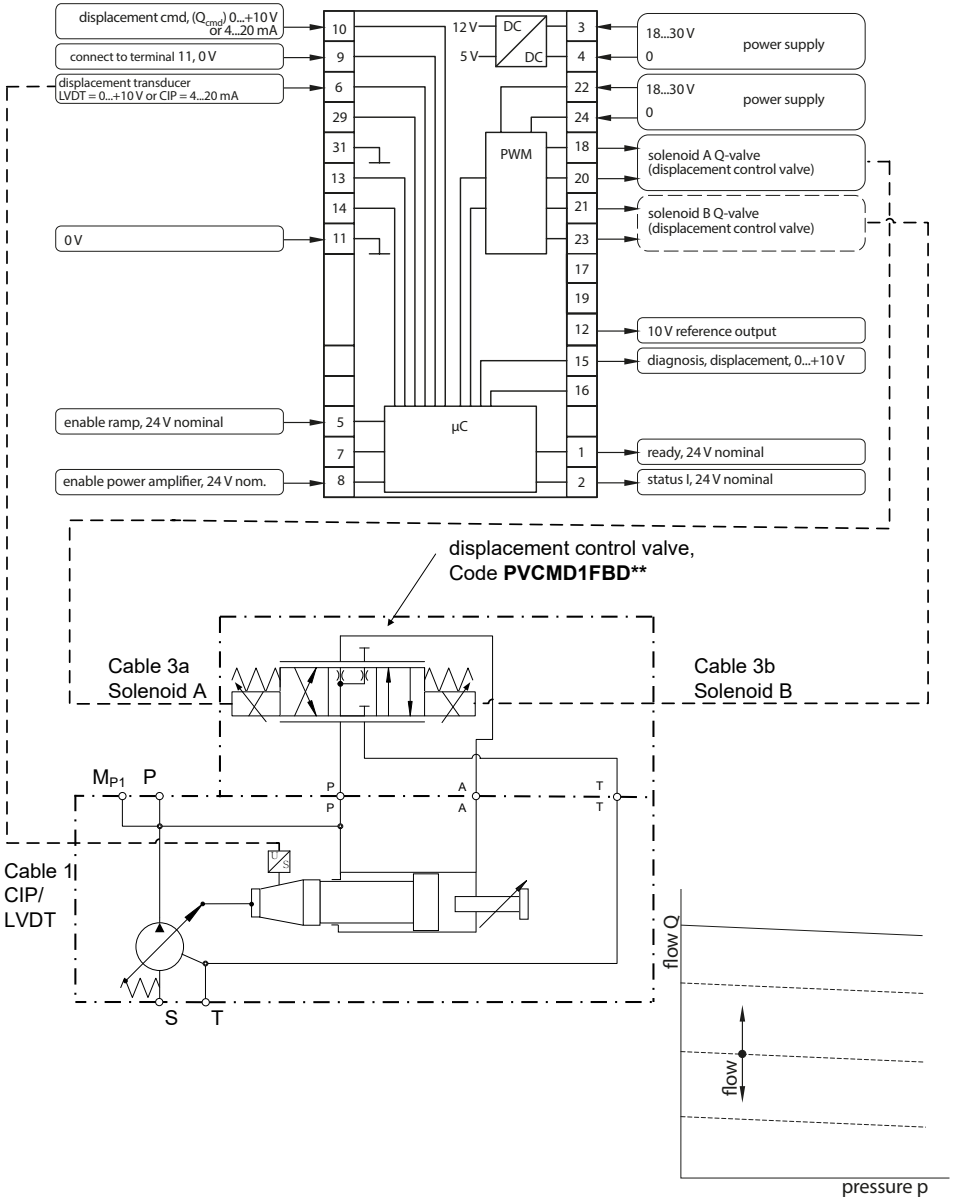

Figure 18: Proportional p-Q-control

**10. Connecting diagram for proportional displacement control; Code ...FDV.**

**Base parameter sets for FDV are available with module firmware PQDXXA-Z10-r03 and higher.** (cable details see chapter 12)



**11. Connecting diagram for p/Q-control; Codes ..UDR, ...UDK, ...UDM, ...UDS, ...UDQ, ... UDP and ...UDF.**

**Base parameter sets for UD\* are available with module firmware PQDXXA-Z10-r03 and higher. (cable details see chapter 12)**

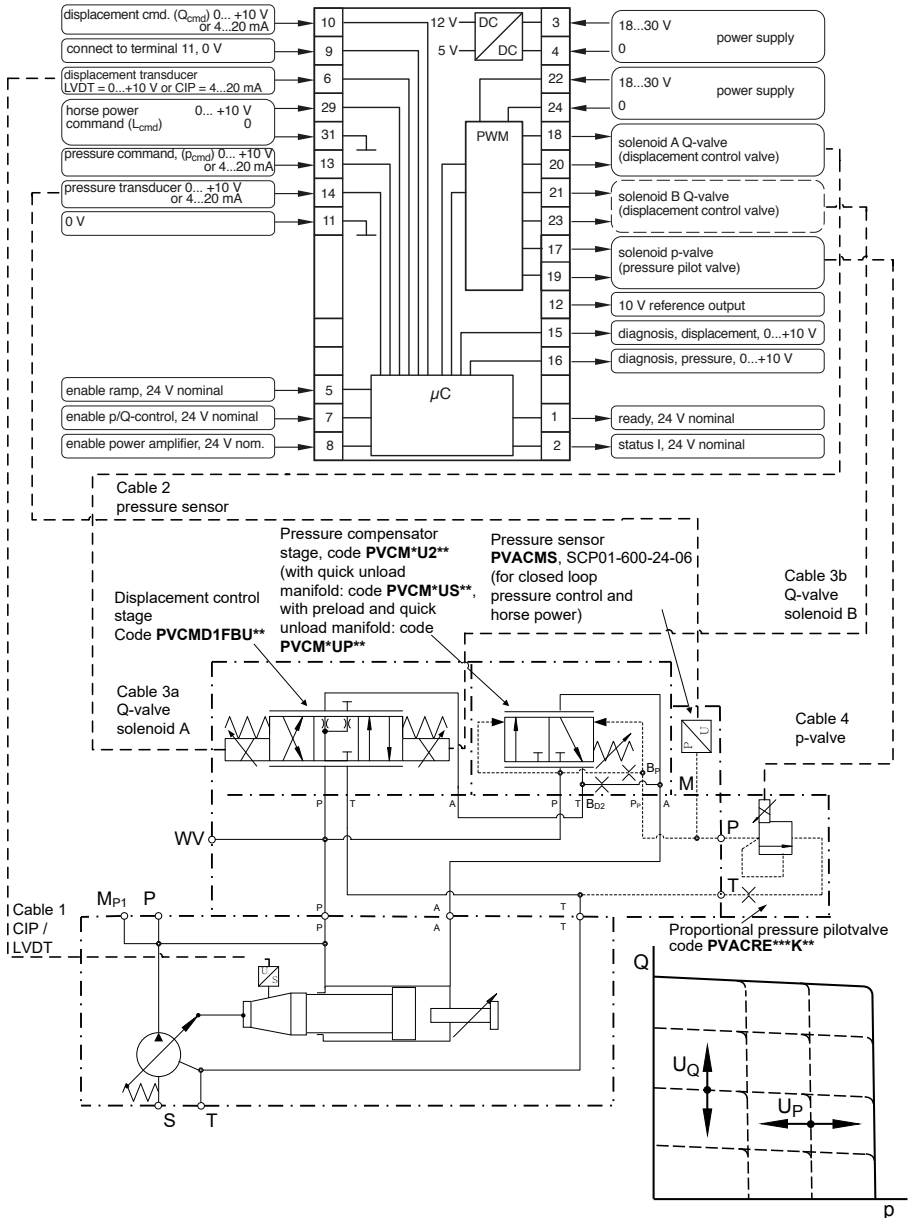

## 12. Cables and connections

### Table 1 from CIP and LVDT (displacement transducer)

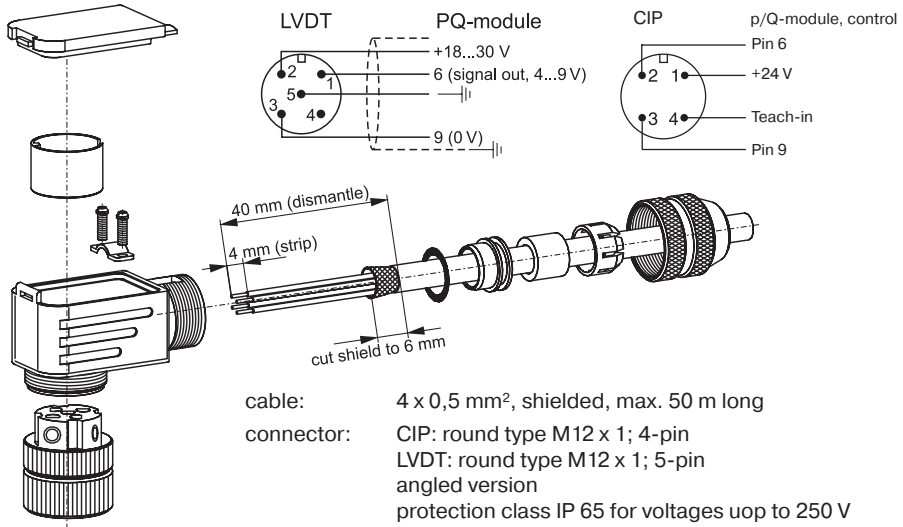

Alternative: shielded cable with molded connector; in different length and variations.

**⚠ Notice:** To protect the sensor, a cable strain relief should be provided on the system side.

### Table 2 from pressure sensor (compensator codes ...UPM, ...UPF, ...UPQ)

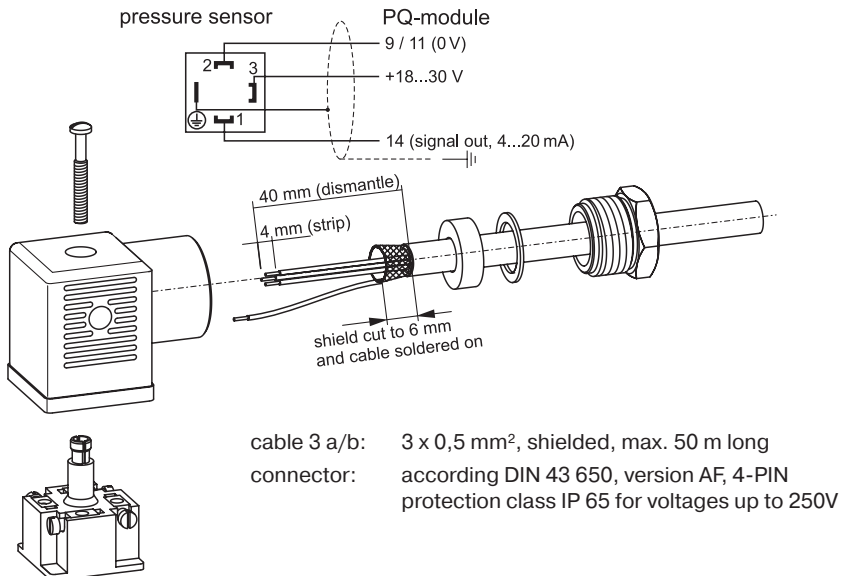

**Cable 3 a/b to displacement control valve (displacement control)**

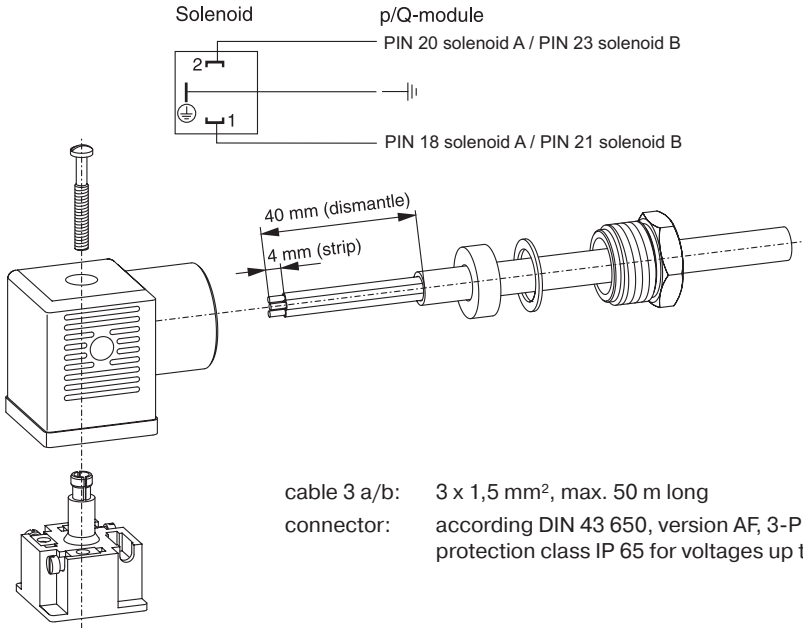

**Cable 4 to proportional pressure pilot valve solenoid (not for compensator code ...FDV, ...UDR, ...UDP, ...UDS [old: ...FPV, ...UPR, ...UPP, ...UPS])**

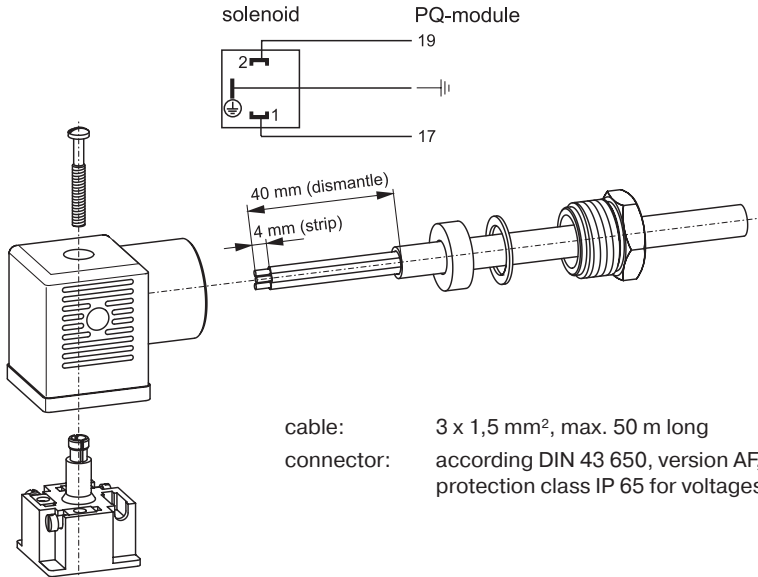

### 13 Trouble shooting guide

<b>Pump delivers no output flow Drive motor does not turn</b>	
reason	Motor is not connected correctly or one of the three phases has failed. Motor does not turn smoothly when pump is disconnected from pump.
solution	<i>Check motor connections, check electrical power supply.</i>
reason	Pump is mechanically blocked. Motor turns smoothly when disconnected from pump.
solution	Send pump for service to factory.
<b>Drive motor only turns at slow speed</b>	
reason	Motor is not selected properly. Installed motor has not enough torque.
solution	<i>Start pump at unloaded system. Use motor with more horse power.</i>
reason	Pump is hydraulically blocked. No function of compensator, no pressure relief valve; Pump stops after a few turns.
solution	Check function of pump compensator (see below). Start pump at unloaded system.
<b>Drive motor turns, pump does not turn</b>	
reason	Coupling is not or not correctly mounted.
solution	Check coupling assembly and correct it.
<b>Drive motor turns and pump turns</b>	
reason	Wrong direction of rotation.
solution	<i>Change direction of motor rotation.</i>
reason	Fluid reservoir empty or not filled to level, suction line ends above fluid level.
solution	<i>Fill reservoir to required level, if necessary increase suction pipe length.</i>
reason	Suction line is blocked. E. g. by plugs, cleaning tissues, plastic-plugs. Ball valve in the suction line closed. Suction filter blocked.
solution	<i>Check suction line for free flow. Open valves in suction line. Valves should be equipped with electrical indicator. Check suction filter.</i>
reason	Suction line not gas tight, pump gets air into suction port.
solution	<i>Seal suction line against air ingress.</i>
reason	Pressure line / system is not able to bleed air out.
solution	Unload pressure port, unload system before start, bleed air from pressure line.
<b>Pump does not build up pressure, but delivers full flow at low pressure</b>	
reason	Standard pressure compensator is set to minimum pressure.
solution	<i>Adjust compensator setting to desired pressure.</i>
reason	No pressure pilot valve connected.
solution	<i>Install suitable pressure pilot valve and adjust it to the desired setting.</i>
reason	Multiple pressure pilot selector valve is not energized; Pump works in stand-by.
solution	<i>Energize selector valve solenoid.</i>
reason	Differential pressure at compensator is adjusted properly (too low).
solution	<i>Check differential pressure adjustment and correct it as described above.</i>



**Trouble shooting guide**

<b>Pump does not build up pressure, but delivers full flow at low pressure</b>	
reason solution	Horse power compensator setting changed. <i>Check setting of horse power compensator and correct it, if required.</i>
reason solution	Proportional displacement control is not connected as required. <i>Check wiring; connect according to installation manual for electronic module.</i>
reason solution	Displacement transducer (LVDT) adjustment changed. <i>Correct zero setting at displacement transducer.</i>
reason solution	Electronic module has no supply power. <i>Make sure module is powered with 22 - 36 V DC.</i>
reason solution	Cylinder block lifts from valve plate due to excessive wear. <i>Send pump to factory for service.</i>
<b>Pump does not compensate</b>	
reason solution	No pressure pilot valve connected to compensator or valve is blocked. <i>Connect pressure pilot valve to compensator, make sure valve opens as required.</i>
reason solution	No or too low pressure at pump outlet port. <i>Pump outlet pressure must be at least 15 bar, because otherwise the bias spring in the pump cannot be compressed.</i>
<b>Pump does not upstroke, sticks at zero displacement.</b>	
reason solution	Compensator is blocked due to contamination. <i>Clean hydraulic fluid, clean compensator valve.</i>
reason solution	Cable to LVDT or proportional solenoid is interrupted <i>Check wiring and make sure cable is ok. Replace if necessary.</i>
<b>Compensator is unstable</b>	
reason solution	Compensator spool is sticking due to contamination of hydraulic fluid. <i>Clean hydraulic system, clean compensator valve.</i>
reason solution	Compensator differential pressure changed (too low or too high) <i>Adjust compensator differential pressure to required setting.</i>
reason solution	Wrong pilot orifice or pressure pilot valve improperly selected. <i>Select pilot orifice and pressure pilot valve as recommended.</i>
reason solution	Dynamic critical system, e. g.: pressure compensator combined with pressure reducing valve, load sensing (flow) compensator combined with flow control valve. <i>use remote pressure compensator instead of standard pressure compensator.</i>





## Position notification regarding Machinery Directive 2006/42/EC:

Products made by the Pump & Motor Division Europe (PMDE) of Parker Hannifin are excluded from the scope of the machinery directive following the "Cetop" Position Paper on the implementation of the Machinery Directive 2006/42/EC in the Fluid Power Industry.

All PMDE products are designed and manufactured considering the basic as well as the proven safety principles according to:

- ISO 13849-1:2015
- SS-EN ISO 4413:2010

so that the machines in which the products are incorporated meet the essential health and safety requirements.

Confirmations for components to be proven component, e. g. for validation of hydraulic systems, can only be provided after an analysis of the specific application, as the fact to be a proven component mainly depends on the specific application.

### Dr. Hans Haas

General Manger

Pump & Motor Division Europe



## WARNING – USER RESPONSIBILITY

**FAILURE OR IMPROPER SELECTION OR IMPROPER USE OF THE PRODUCTS DESCRIBED HEREIN OR RELATED ITEMS CAN CAUSE DEATH, PERSONAL INJURY AND PROPERTY DAMAGE.**

This document and other information from Parker-Hannifin Corporation, its subsidiaries and authorized distributors provide product or system options for further investigation by users having technical expertise.

The user, through its own analysis and testing, is solely responsible for making the final selection of the system and components and assuring that all performance, endurance, maintenance, safety and warning requirements of the application are met. The user must analyze all aspects of the application, follow applicable industry standards, and follow the information concerning the product in the current product catalogue and in any other materials provided from Parker or its subsidiaries or authorized distributors.

To the extent that Parker or its subsidiaries or authorized distributors provide component or system options based upon data or specifications provided by the user, the user is responsible for determining that such data and specifications are suitable and sufficient for all applications and reasonably foreseeable uses of the components or systems.

## Offer of Sale

Please contact your Parker representation for a detailed "Offer of Sale".

**For additional information, spare parts or service requirements please contact:**

### Parker Hannifin Manufacturing Germany GmbH & Co KG

Pump & Motor Division Europe

Neefestraße 96

09116 Chemnitz, Germany

Tel: +49 (0)371 - 3937 - 0

Fax: +49 (0)371 - 3937 - 488

Email: pmde-pqd-support@parker.com

parker.com/pmde

MSG30-3254-INST/UK



© Copyright 2021  
All rights reserved